

**Association of Interior Specialists
Construction Fixings Association**

BEST PRACTICE GUIDE
**selection and installation of top
fixings for suspended ceilings**

Association of Interior Specialists Construction Fixings Association

BEST PRACTICE GUIDE

selection and installation of top fixings for suspended ceilings

www.ais-interiors.org.uk

www.the-cfa.co.uk

Supported by



First edition published May 2012
ISBN 978-0-9565341-3-2

World copyright reserved

Copyright © 2012
Association of Interior Specialists

Published by Association of Interior Specialists

No part of this document may be reproduced or transmitted in any form or by any means electronic, chemical or mechanical, including photocopying, any information storage or retrieval system without licence or other permission in writing from the copyright owner.

While every care has been taken to ensure the accuracy of the details presented in this document, we regret that AIS cannot be held responsible for any errors or omissions contained herein.

Contents

1	Foreword	4	Fixing selector chart for suspended ceilings	14	7	Terminology	25	
2	Introduction	5	5	Top fixing types and installation procedures	16	8	Contracting support administration	28
2.1	Background	5	5.1	Anchors	16	8.1	Sustainability	28
2.2	Scope	5	5.1.1	Drop-in expansion anchors	16	8.2	Health and safety	28
3	Responsibilities	6	5.1.2	Force controlled expansion anchors	17	8.3	Operation and maintenance (O&M) manuals	28
3.1	Contractual responsibilities	6	5.1.3	Hammer-in anchors - steel	17	9	References	29
3.2	Statutory responsibilities	6	5.1.4	Hammer-in anchors - nylon (plastic)	17	10	Appendix	30
4	Top fixing selection	7	5.1.5	Cavity anchors	18	10.1	ETAG 001: Metal anchors for use in concrete Part 6: Anchors for multiple use in non-structural applications	26
4.1	Identify the application parameters	7	5.2	Screws	18	11	Acknowledgements	31
4.1.1	Know the applied load	7	5.2.1	Nylon (plastic) plugs and screws	18			
4.1.2	Identify the base material (substrate)	8	5.2.2	Self-tapping concrete screws	18			
4.1.3	Environmental factors	9	5.3	Clips and clamps	18			
4.2	Check the structure will support the applied load	10	5.4	Powered fasteners	18			
4.3	Robustness and redundancy	10	5.4.1	Powder actuated fasteners	18			
4.3.1	Perimeter trim fixing	10	5.4.1.1	Standard installation method	19			
4.4	Selecting the top fixing type	11	5.4.1.2	Pre-drilled system	20			
4.4.1	Suitability for the base material	11	5.4.1.3	Fixings into structural steelwork	21			
4.4.2	European Technical Approvals (ETAs)	11	5.4.2	Gas powered fasteners (gas nailing)	21			
4.5	Check fixing load capacity	12	5.5	Cast-in channel	21			
4.5.1	Cases where the recommended load of the chosen top fixing is known	12	5.6	General installation	22			
4.5.2	Cases where the recommended load of the chosen top fixing is not known	13	5.6.1	Hole dimension	22			
4.6	Specification of the selected top fixing	13	5.6.2	Embedment depths	22			
4.7	Corrosion of top fixings	13	5.6.3	Competent installer scheme	22			
4.7.1	Stress corrosion in swimming pool roof spaces	13	6	Testing top fixings on site	23			
			6.1	Preliminary tests	23			
			6.2	Proof tests	23			
			6.2.1	Fixings other than powder actuated fasteners	23			
			6.2.2	Powder actuated fasteners	24			

Foreword

This guide to the selection and installation of top fixings for suspended ceilings has been developed by the Association of Interior Specialists (AIS) and the Construction Fixings Association (CFA), in conjunction with the Standing Committee on Structural-Safety (SCOSS) and other industry experts, as a guide to best practice on the choice, installation and testing of fixings for suspended ceilings.

There are very few commercial building projects, new build or refurbishment, which do not have suspended ceilings as one of their key construction components. Usually representing the largest uninterrupted surface, they make a major contribution to the overall appearance and acoustic quality of the finished space.

The importance of top fixings cannot be overstated as they are critical to the safety and security of suspended ceilings and associated equipment. There have been many failures in the UK and elsewhere of top fixings which have resulted in the collapse of ceilings. The costs and impact of a collapse can be huge and affect the lives of those involved whether they are victims or those who are responsible for the failure. Failures involving death or serious injury may also result in prosecutions. Using the correct approach and ensuring the proper selection and installation of top fixings is key to reducing risks.

Suspended ceilings are a finishing trade and require installation by specialist contractors. The specialist contractor will provide the high levels of management, operative skills and resources, essential to deliver a high quality product. Their considerable experience on similar projects will be of significant assistance to the construction team.

This Best Practice Guide for the selection and installation of top fixings for suspended ceilings is not intended as a definitive technical manual, as the manufacturers' recommendations must always be followed, but as a guide to the construction team as to best practice. AIS and CFA encourage all involved to follow the principles set out in this guide.

TOP 10 REASONS WHY CEILINGS COLLAPSE

- 1 Incorrect selection of fixing
- 2 Incorrect installation of fixing
- 3 Additional load applied
- 4 Insufficient number of fixings
- 5 People walking/crawling on ceilings
- 6 Failure to follow manufacturers guidance/instructions
- 7 Modification by other trades
- 8 Insufficient supervision/training
- 9 Structural vibration causing fixings to fail
- 10 Substitution of specified components

Source: AIS member survey 2010

Introduction

A satisfactory suspended ceiling installation must fulfil three main requirements:

- Appearance
- Function (performance)
- Structural stability

These can only be achieved when the correct top fixings are specified and installed correctly. However, ceiling fixings tend to be considered as secondary items on many projects. They often suffer from insufficient attention by designers and installers, and are not accorded due attention throughout the contract. This guide seeks to address this.

There are many elements that need to be considered when specifying top fixings. These include for example, substrate, access, accuracy of anticipated loading, and the ability to accommodate an individual failure without this leading to progressive collapse of the ceiling. All are discussed within this guide.

2.1 Background

AIS has grown over the past 50 years to become the leading trade association for the interiors fit out sector of the construction industry, representing companies involved in the manufacture, supply and installation of all aspects of interior fit out and refurbishment. It is committed to raising and maintaining industry standards.

The CFA represents the major manufacturers of fixing systems which are set in drilled holes in all construction materials including concrete, brickwork, blockwork, stonework and plasterboard - many with European Technical Approvals (ETAs). Its mission is to ensure best practice in fixings.

Structural-Safety, incorporating the Standing Committee on Structural Safety (SCOSS) and the Confidential Reporting on Structural Safety (CROSS), has had an interest in ceiling fixings for some time. This interest arose in part from reports received by CROSS which exemplified significant failures of fixings. It has worked closely with AIS and CFA to produce this document.

2.2 Scope

This guidance covers the use of top fixings for the suspension of suspended ceilings only. Cable trays, ductwork, lighting, air handling units and all other ancillaries must be independently supported and are therefore not covered by this document.

The term 'top fixing' is used to describe all manner of fixings used for the suspension of hangers / brackets used in the installation of suspended ceilings. The term 'anchor' refers to a specific type of fixing mainly used when fixing into concrete.

The recommendations set out in 'BS 8539-2012: Code of practice for the selection and installation of post-installed anchors in concrete and masonry' form the basis of much of this guidance when referring to fixing into concrete soffits. (Currently in draft form - due for publication at the end 2012.)

The terminology used in this guide is that typically used in the industry and may not coincide in every case with that used in BS 8539, where it does not the equivalent term is listed in Section 7 Terminology.

Section 4.3.4 and Annex B of 'BS 13964: Suspended ceilings - requirements and test methods' are also taken into consideration.

The Building Regulations (England and Wales), Approved Document A - Structure, specifically mentions the use of approved anchors for cladding fixings (Section 3 Wall Cladding). However, the general emphasis of the text in this document is on the proven performance of the fixing in the relevant material and consideration of the attendant risks.

There is no specific reference to fixings in the Northern Ireland or Scottish Technical Standards, though of course through the use of the Structural Engineers Register (SER) route in Scotland a Chartered Engineer, as Certifier of Design, takes responsibility for all structural elements.

This guide is written for anyone who will either specify the top fixing used to support a suspended ceiling, or who will install or test a specified top fixing. All tasks outlined in this guide are expected to be carried out by competent persons.

Responsibilities

It is essential at all stages in the process of selecting, designing, specifying, installing and testing of fixings, that it is clear which party (or person) has responsibility for which actions. Although the party may change over the course of the project, only one party (or person) can be responsible for a specific aspect at any one time.

Responsibilities may be contractual or statutory although the latter overrides the former.

3.1 Contractual responsibilities

Contractual responsibilities will vary from contract to contract. However, it must be explicitly clear which party:

- Selects and designs the specific fixing
- Specifies the fixing in NBS K10/K40
- Installs the fixing
- Tests the fixing

If a contractor is asked to do more than just install (or install and test), then it will have a 'design element' to its appointment. In this case the contractor must be supplied with information by the designer/specifier on:

- Any restrictions on choice
- Load cases to be accommodated (eg imposed load requirements, future provisions)
- Any other performance requirements
- Details of the substrate

It is important that those compiling contract terms ensure that the requirements of all parties are unambiguous and inclusive.

3.2 Statutory responsibilities

These derive from the Construction (Design and Management) Regulations 2007. The party selecting, designing or specifying the specific fixing is a 'designer' as defined by these Regulations and has duties under Regulation 11. Guidance on designer duties is given at http://www.cskills.org/uploads/CDM_Designers4web_07_tcm17-4643.pdf

These duties include the elimination of hazards and reduction of risk, as far as is reasonably practicable. They also require information on significant residual risks to be passed on.

Designers have a responsibility to co-operate with other designers (regardless of whom appoints them) and to coordinate their designs. This may involve the services designer (in respect of duct positions or access into the ceiling void).

The party installing or testing the fixing is a 'contractor' as defined by the Regulations. The contractor has responsibilities for the safe execution of the work on site so that those involved, or otherwise affected, do not have their safety or health compromised.

Generally both parties (designer and contractor) have a duty to supply the CDM coordinator with relevant information for the health and safety file.

COMPETENCY

Persons involved in all aspects of top fixing, including specification, installation and testing, should be competent.

Top fixing selection

APPROACH TO ENSURE SAFE ANCHORAGE

Identify the application parameters (see 4.1)

Check the load bearing structure will support the applied load (see 4.2)

Check the need for redundancy in the supported structure (ceiling grid) (see 4.3)

Select fixing type (see 4.4, 5)

Check fixing load capacity (see 4.5)

Recommended load of the fixing known for the specific base material

Recommended load of the fixing unknown for the specific base material

Check the applied load is lower than the recommended load

Find recommended load from preliminary tests on site (see 6.1) - check the applied load is lower than recommended load

Specify the selected fixing in project documentation (see 4.6)

Specified fixing to be installed in accordance with manufacturer's instructions (see 5)

Sample of fixings on EVERY job to be proof tested (see 6.2)

4.1 Identify the application parameters

Before beginning the top fixing selection process it is important to identify the application parameters. These include the applied load, the base material that the top fixing will be fixed into, and any environmental factors that may affect the ceiling or the fixing after installation.

4.1.1 Know the applied load

For the purposes of this guide the following descriptions and weight bands are used.

Type of suspended ceiling	Maximum dead load
Light weight	Less than 10kg/m ²
Medium weight	10kg/m ² to 30kg/m ²
Heavy weight eg multilayer plasterboard	Greater than 30kg/m ²

Fluctuations in air pressure caused by wind or large opening doors may increase the load on the fixing.

Top fixing selection

4.1.2 Identify the base material (substrate)

Before selecting a fixing it is important to identify the base material (section 5 indicates suitable base materials for different fixing types), as not all fixings are suitable for all base materials (see selector chart). Checks should also be made for the presence of asbestos.

Typical base materials include:

CONCRETE

The type of concrete structure should be considered as there may be factors which could influence the choice of top fixing or its positioning. Anchors are the recommended top fixing for concrete.

CAST IN-SITU AND PRE-CAST CONCRETE

Cast in-situ concrete is the most common concrete structure for which most anchors are suitable. Most anchors claimed by the manufacturer to be suitable for in-situ cast concrete may also be suitable for solid pre-cast concrete. Specialist anchors may be required in hollow pre-cast concrete. It is important to consider the presence of pre-tensioning wires which may be in some pre-cast sections, particularly hollow core floor beams. The high tension induced in these wires means care must be taken to ensure they are not drilled into. Anchor positions should be specified to avoid this.

CONCRETE BLOCKS

The factors outlined for masonry in BS 8539 should be taken into account when selecting fixings to be installed in concrete blocks.

CRACKED CONCRETE

It is normal for concrete to crack (cracks will be no more than 0.3mm wide and generally invisible to the naked eye) and this is allowed for in design.

As the underside of the concrete structures eg soffits are under tensile stress, these should be regarded as cracked. Fixings selected should therefore be qualified for use in cracked concrete.

Anchors are available with European Technical Approval (ETA) which are qualified for use in both cracked and non-cracked concrete (ETA to ETAG 001 Parts 1-5, options 1-6). Those qualified to ETAG 001 part 6 are particularly suitable for use with suspended ceilings see section 4.4.2 and 10.1.

COMPOSITE CONSTRUCTION

Composite construction is taken to mean a concrete floor slab cast on top of metal decking forming not only permanent shuttering but interlocking with the concrete to carry the floor or roof loading. The concrete may be normal weight dense aggregate concrete or lighter weight concrete.

Modern deck profiles used in composite construction have increased steadily in depth from 50mm for spans up to 3.6m to currently 80mm for longer span applications.

Consequently, slab depths have also increased from typically 130mm to 150mm. Re-entrant portions are often rolled into the top or bottom of the deck profile to facilitate service attachments.

Fixings may be made through the steel decking into the concrete eg powder actuated fastenings or may use wedge shaped elements located into inverted wedge shapes formed in the underside of the metal decking. Alternatively drilled in

fixings may be installed in holes drilled through the decking into the concrete.

LIGHTWEIGHT STEEL FRAMING

Light steel frames are constructed using light steel components, typically of C or Z section of 70mm to 200mm depth and 1.2mm to 2.4mm thickness.

METAL DECKING

Steel decking is a fabricated, roll formed material which has a ribbed or corrugated profile. It is used as floor and roof assemblies. Fixings are installed with self-drilling and tapping screws, or proprietary wedge nuts located into the profile of the decking.

HOLLOW POT FLOOR

The slab will be one way spanning (on to beams or load-bearing walls) with reinforced concrete ribs supporting the hollow blocks. The overall thickness will include a reinforced concrete topping of between 75mm to 100mm thickness.

Fixings are available which work in hollow pot floors based on cavity type fixings using toggling and other mechanisms.

BEAM AND BLOCK

The system comprises pre-stressed, inverted T-beams, infilled with blocks of different densities. Beams are produced to give nominal depths from 150mm to 225mm and are placed at 520mm and/or 295mm centres depending on span and load. The completed floor is grouted with a sand/cement mixture. Because of the variety of materials, densities and presence of rebar, specialist advice should

Top fixing selection

be sought in the selection of fixings in this situation.

Different top fixing types may be needed for the beam and the block so great care will be needed in specifying the top fixing and in ensuring that the correct fixing is installed in each material.

TIMBER

Timber may be encountered as a joist and as a complete floor; care should be taken to avoid any services within a floor void. Because of the various species of timber and age of the building, different densities of wood may be present. The specifier therefore should carry out preliminary tests on site to determine the suitability and allowable load of the proposed woodscrew or through bolt (see 6.1).

As timber ages, type and quality is considerably variable, good practice would always be to test on site the performance of any proposed fixing with the timber. Fixing into timber should always be undertaken with good quality woodscrews, manufactured to BS 1210 or in certain applications, vine eyes.

Joists: it is preferable to make fixings to the side of the joist in shear, up at least 50mm from the bottom edge and penetrating the joist by a minimum of 38mm if possible. If fixing is to be made to the bottom of the joist then a good quality woodscrew can be used to fix an angle bracket to the underside of the joist.

Alternatively vine eyes can be used, providing that the ceiling is being suspended by wire and that the same penetration is achieved. In cases where the joist is clad with a board product such as plasterboard, care should

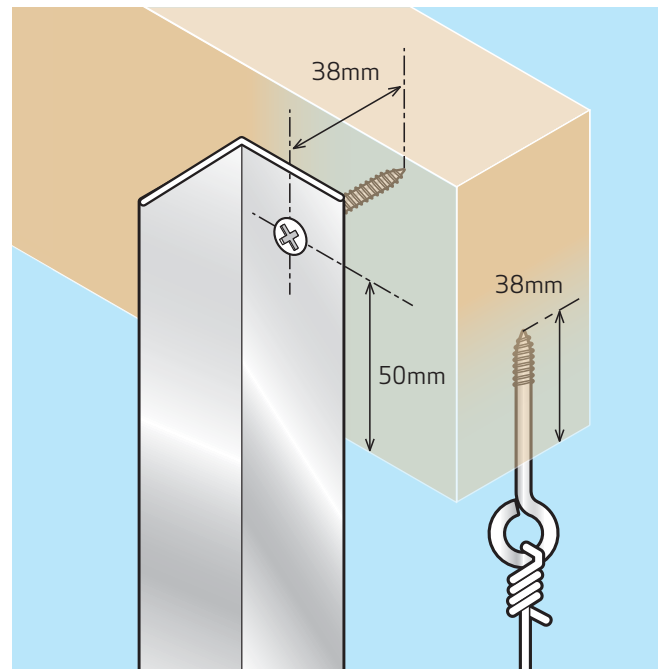

Figure 1

be taken in selecting the correct screw length to ensure that at least 38mm still penetrates into the joist (see figure 1).

Timber floors: the above principles apply but care should also be taken when screwfixing to avoid any services that may be in the floor void running parallel to or through joists.

WOODWOOL

Woodwool slab (formed from long-fibre wood shavings compressed and bound together with cement) is not considered to be a suitable substrate from which to fix/hang suspended ceilings.

4.1.3 Environmental factors

Environmental considerations which may influence fixing choice include conditions which may cause corrosion, elevated temperatures, fluctuations in pressure and the need for a fire rating.

CORROSION CONDITIONS (HIGH HUMIDITY)

See section 4.7 for recommendations.

ELEVATED TEMPERATURES

The only fixings likely to be affected by elevated service temperatures are nylon anchors. Specialist advice from the manufacturer should be sought for elevated temperatures above 40°C.

VIBRATION

Where vibrations may be present, for example where there is adjacent plant or machinery, or where road and rail traffic are closely adjacent or above the soffit, specialist advice should be sought from the fixing manufacturer.

FIRE RATING

Few top fixings are available with a fire rating as such. Some are available with European Technical Approvals (ETAs) which cover resistance to fire and others with independently verified data based on tests carried out to standard fire curves which sets out durations for which certain loads can be supported. Where a fire rating is required, specialist advice should be sought from the fixing manufacturer. Alternatively secondary fire protection may be applied to the fixing post installation.

4.2 Check the structure will support the applied load

The guidance given here is based on the assumption that all fixings will be fixed into, and the loads involved supported by, a load bearing structure capable of sustaining the required loads, ie structural soffit and/or adjacent wall.

If there is any doubt as to the suitability of the structure then the advice of a qualified structural engineer should be obtained before proceeding with the selection process. In certain cases the load bearing nature of the structure may be clear but the specific loading capability of a particular fixing in the base material of that structure may not be known ie there may be no recommended load quoted by the manufacturer of the fixing. This may be due to a number of factors. For example the overhead load bearing structure may be a hollow pot floor, or an adjacent wall (for the fixing of perimeter trim) may consist of some sort of block work of unknown strength. In such cases it may be necessary to carry out preliminary tests to determine the allowable load of the proposed fixing in this specific base material (see 6.1).

4.3 Robustness and redundancy

Robustness means having sufficient redundancy in the system such that one isolated failure does not result in the excessive overloading of other fixings leading to progressive collapse. Failure might be due to accidental overloading, impact, poor design or installation, unreliable substrate condition, or corrosion. The Institution of Structural Engineers has published a very useful guide to robustness in general called 'Practical guide to structural robustness and disproportionate collapse in buildings (2010)': shop.istructe.org

Normally the design should be based on the assumption that if one fixing were to fail then all loads being carried by that fixing will be adequately transferred to surrounding fixings which must then be capable of sustaining the additional load. If the ceiling system has continuous members (tee sections) supported from fixings then these may assist in the re-distribution of load in the event of a failure of one fixing.

Where there are heavy ceilings over spaces which may be used by the public or by other persons then a risk assessment should be carried out by the designer. Scenarios should be envisaged such as the failure of a fixing or fixing point and consideration of the possible consequences. When possible the risk should be eliminated but if this cannot be done then the risk must be minimised. If a fixing fails, for whatever reason, then the resulting additional load (possibly including an element of dynamic load) must be accommodated by the immediately adjacent fixing points. If this is not the case then progressive collapse may occur

as the ceiling 'unzips' and falls. There may be a difference between a fixing failing at an end support and one failing in the middle of a row of fixings. If failure of a fixing at an end support is considered to be an undue risk it may be appropriate to increase the number of fixings or use more substantial fixings at such points.

ETAG 001 Part 6 deals with the use of multiple use fixings (see 4.4.2) into concrete, selecting an anchor with such an ETA will simplify substantially considerations of redundancy (see 10.1).

4.3.1 Perimeter trim fixings

Perimeter fixings for trims and battens should be selected and installed in line with the 'AIS Best Practice Guide: installation of suspended ceilings'. As several failures of suspended ceilings have started with the failure of edge trim fixings their contribution toward the redundancy of the overall suspension system should be taken into account. This may mean using additional fixings.

Top fixing selection

4.4 Selecting the top fixing type

There are several factors which contribute to this decision as to which top fixing to select including suitability for the base material and the need to select, where possible, a fixing with an ETA. Corrosive conditions are also a factor (see 4.7).

4.4.1 Suitability for the base material

Not all fixings are suitable for all the base materials which may be encountered in a structural soffit. The manufacturer of any fixing being considered for anchoring of a suspended ceiling should state clearly which base materials the fixing is suitable for and, as long as the strength of that base material is quantifiable, the appropriate recommended load.

A guide to various fixing types is given in section 5. However, manufacturer's guidance should be checked and takes precedence over any guidance contained within this document.

4.4.2 European Technical Approvals (ETAs)

Many anchors (see 5.1) are now available with European Technical Approvals (ETAs) which are only awarded after a rigorous test regime. Anchors which have been awarded ETAs to ETAG 001: Metal anchors for use in concrete (Parts 1-5) may be qualified for use in both cracked and non-cracked concrete (Options 1-6) or in non-cracked concrete only (Options 7-12).

Anchors with ETAs to ETAG 001: Metal anchors for use in concrete (Part 6 - anchors for multiple use for non-structural applications) are qualified for use in cracked and non-cracked concrete. This part of the ETAG is concerned with multiple use of anchors and is specifically aimed at the application of top fixings for suspended ceilings. For more information on ETAs to ETAG 001 Part 6 (see 10.1) which explains the basis by which applications may qualify as being 'multiple use'.

It is preferable to select an anchor with an ETA as these will have been exhaustively tested to prove their functioning in a wide range of site conditions and will have reliable and comparable load data. BS 8539 effectively recommends that where a suitable anchor with an ETA is available that should be specified.

Top fixing selection

4.5 Check fixing load capacity

4.5.1 Cases where the recommended load of the chosen top fixing is known

For anchors, the approach set out in BS 8539 for determining the anchor size once the anchor type has been selected should be used. For anchors with an ETA the design method applicable to the ETA should be followed.

For fixings without an ETA, the key design criterion derived from BS 8539 (albeit using different terminology) can be stated as **APPLIED LOAD ≤ SAFE WORKING LOAD**.

Figure 2: tensile

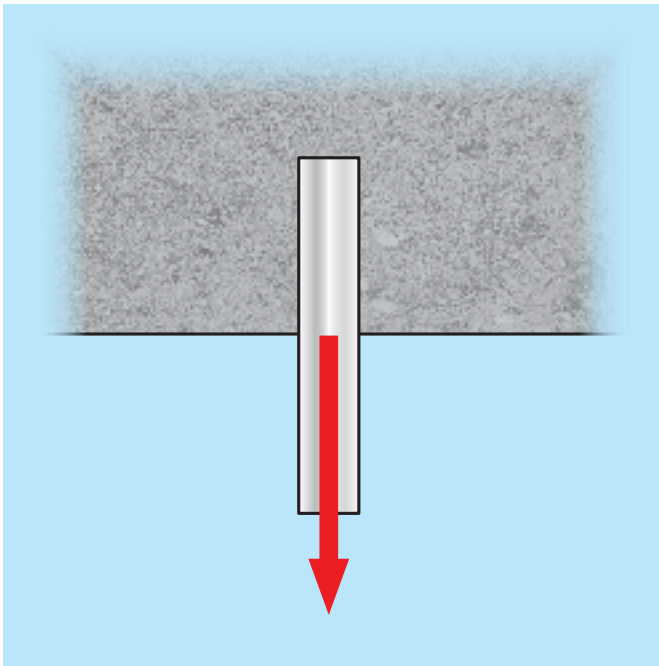

This consideration must be satisfied for whichever direction the load is applied.

The safe working load is usually referred to by the fixing manufacturer as the recommended load. When there is no recommended load data available eg when the base material is of unknown strength then the allowable load specific to that base material can be determined from preliminary tests as outlined in section 6.1.

LOADING DIRECTION

In general loads may be applied to top fixing either in

Figure 3: shear

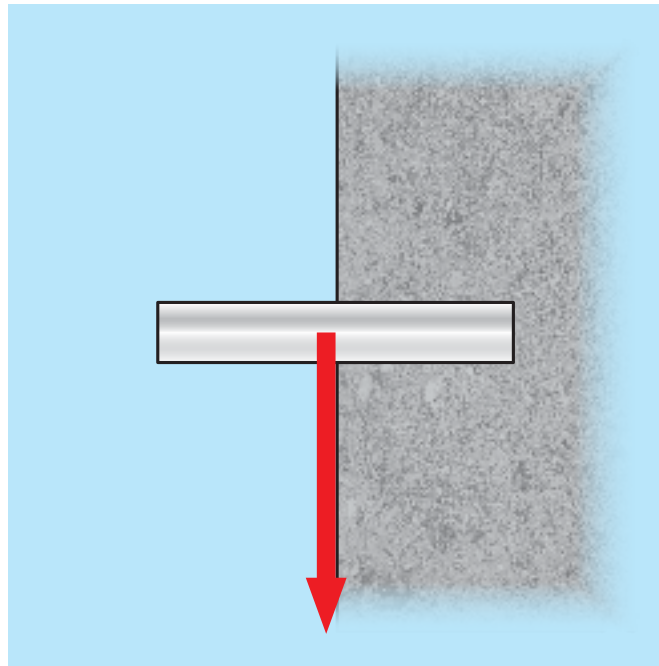

tension or shear, or the two combined (**see figures 2, 3 and 4**). In suspended ceilings the top fixings effectively take tensile loads only. Perimeter edge trim fixed to a wall may be subject to shear only or, in rare cases, to a combination of tensile and shear loads, in which case a combined load check must also be carried out - refer to the manufacturer. Some fixings intended for use as top fixings for suspended ceilings have very poor shear capacity so different fixings may need to be chosen for fixing perimeter trim.

Figure 4: combined tensile and shear

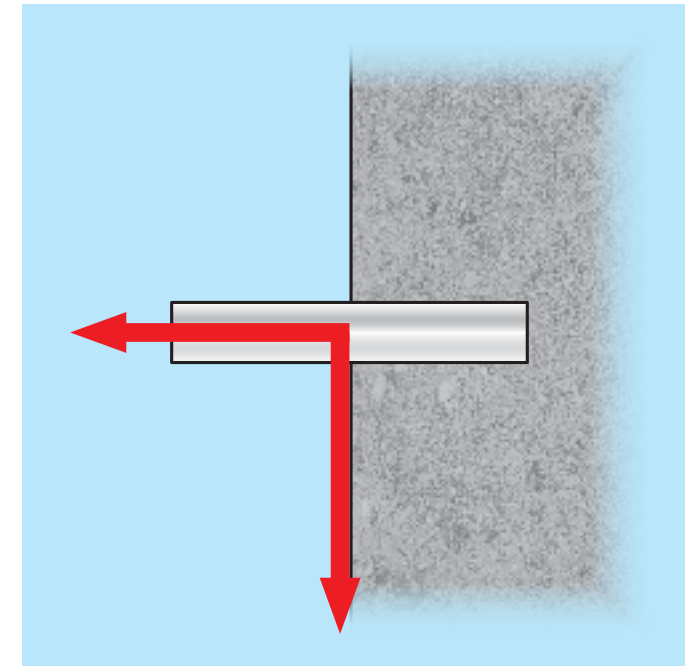

4.5.2 Cases where the recommended load of the chosen top fixing is NOT known

If there is no recommended load data quoted by the manufacturer (unlikely in the case of fixings intended for concrete) then the allowable load for the proposed top fixing in the base material of the site may be determined from tests carried out on site according to the procedure for preliminary tests (see section 6.1). This is not necessary in the case of concrete structures, even if they are old and their strength is unknown, as concrete gains strength as it ages and is likely to have performance matching or exceeding that quoted by manufacturers for a nominal compressive strength of 30N/mm². It may be necessary for instance in the case of beam and block ceilings where top fixings are required to be made into the block infill panels.

4.6 Specification of the selected top fixing

Once the top fixing is chosen its specification should be detailed in project documentation sufficiently to ensure that the correct top fixings are acquired by the contractor and with all necessary installation detail to ensure correct installation. More guidance on the selection and specification of anchors can be found in BS 8539.

WARNING there is evidence that some counterfeit products have come on to the market which may have false documentation. It is the contractor's responsibility to ensure that all products should be from the specified manufacturers. Sourcing products from distributors nominated by the specified manufacturer may help to avoid the acquisition of counterfeit products.

4.7 Corrosion of top fixings

If there is any humidity in the atmosphere, as may exist in kitchens for instance, stainless steel fixings should be used. If the humidity is significant then specifically grade A4 stainless steel should be used and suspension components to suit. The most common grades of stainless steel for A4 fixings are 1.4401 and 1.4404. Grades 1.4432, 1.4436 and 1.4435 also fall within the scope of A4. A5 fixings, grade 1.4571, can also be used.

4.7.1 Stress corrosion in swimming pool roof spaces



In areas of high humidity with elevated temperatures and in the presence of chlorides, eg swimming pool roof spaces, then stress corrosion is likely and normal grades of stainless steel will not be suitable. Special alloys with higher concentrations of chromium and molybdenum should be used. Designations of suitable alloys are: 1.4565; 1.4529 and 1.4547.

More information and clarification can be found at the British Stainless Steel Association (BSSA) website

www.bssa.org.uk/sectors.php?id=34

FIXING SELECTOR CHART FOR SUSPENDED CEILINGS

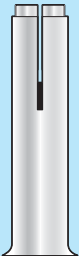
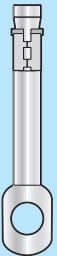
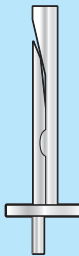
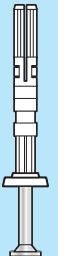
In all cases, recommended load range varies with diameter and base material.

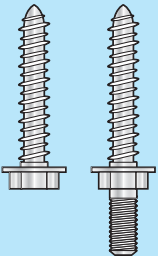
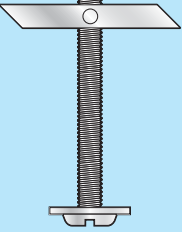
	DROP-IN EXPANSION ANCHOR	FORCE CONTROLLED EXPANSION HANGER	HAMMER-IN ANCHOR STEEL	HAMMER-IN ANCHOR NYLON	NYLON PLUG AND SCREW	SELF-TAPPING CONCRETE SCREWS	CAVITY ANCHORS
Fixing into...							
Concrete	L M H	L M H	L M H	L M H	L M H	L M H	
Hollow core concrete	L M H	L M H	L M H	L M H	L M H	L M H	L M H
Composite deck	L M H	L M H	L M H	L M H	L M H	L M H	
Hollow pot				L M H	L M H	L M H	L M H
Beam and block		L M H		L M H	L M H	L M H	L M H
Metal decking							L M
Lightweight steel framing							L
Structural steelwork							
Timber						L M H	
For a commentary on the various base materials see section 4.1.2	Drop in anchors can have a straight or flared end. Only the flared end versions may be suitable for use in hollow concrete.			Fixings made from nylon may not be suitable for fire conditions unless qualified appropriately by an ETA or supplied with independently verified test data according to recognised fire curves.		Self-tapping concrete screws are not all suitable for fixings in hollow pot. This must be checked with the manufacturer.	Cavity anchors may be used in the blocks of beam and block ceilings only if blocks are hollow.

Top fixing selection

Ceiling class: **L**ight, **M**edium or **H**eavy



= suitable for use



= use with caution

BLANK = **DO NOT USE**

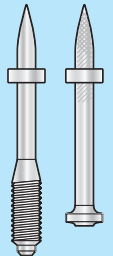
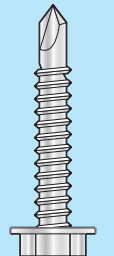
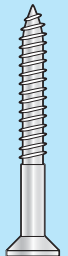
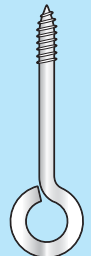
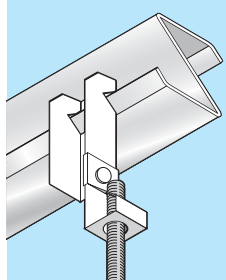
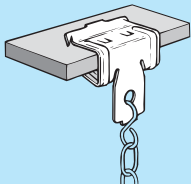
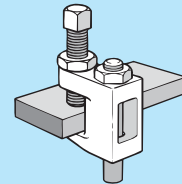
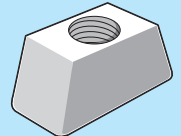
POWDER ACTUATED SYSTEMS	SELF-DRILLING AND TAPPING SCREWS	WOODSCREWS	VINE EYES	PURLIN CLIPS	BEAM CLIPS	BEAM CLAMPS	WEDGE NUTS
							
L M H							
L M H	← ALL fixings into hollow core concrete need care to avoid drilling into pre-stressing wires and to ensure holes are drilled into the core.						
L M H							
← Wire hangers should only be installed into the beam of beam and block structures.							
	L M H						L M H
	L M H			L M H	L M H		
L M H	L M H			L M H	L M H	L M H	
		L M H	L M H				
	Self-drilling and tapping screws for steel are generally limited to a maximum steel thickness of 12.5mm, depending on the length of the drill point.			Purlin clips have a load capacity of 70kg but may be limited by distortion of the purlin.	Beam clips have a load capacity of 65 to 90kg. There are heavy duty systems available.		

Top fixing types and installation procedures

The top fixings discussed here are those currently used within the industry and considered suitable subject to the qualifications outlined. Other types not listed may be equally suitable.

5.1 Anchors

Anchors are primarily used for fixing into concrete. It is preferable to select an anchor with an ETA as these will have been exhaustively tested to prove their functioning in a wide range of site conditions and will have reliable and comparable load data (see 10.1).

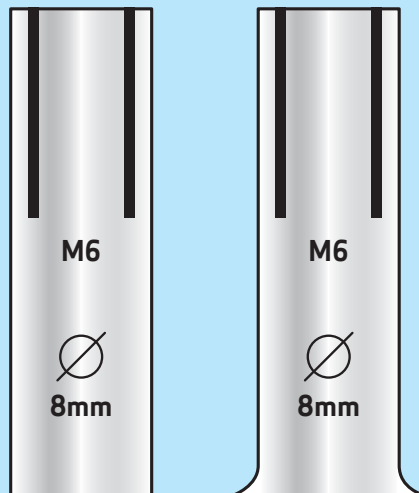

5.1.1 Drop-in expansion anchors

The traditional drilled anchor for suspension of all sorts of services using drop-rods, including suspended ceilings toward the heavier end of the scale. The M6 size is appropriate. Drop-in anchors should only be used in concrete.

Drop-in anchors are expanded by hammering a pre-assembled expander plug to the base of the anchor using a special setting punch. They may also be used with bolts or machined screws in which case the thread length of the bolt or screw must be chosen to suit the fixture thickness. The internal thread length (as recommended by the manufacturer) should be sufficient to ensure there is enough

Figure 5: drop-in internally threaded, hammer set expansion socket anchor

- For concrete only
- Ideal for use with drop-rods.
- May not be used in brickwork or other forms of masonry

Right: The lipped, or flanged version sits flush with the surface so may not be set deep in the concrete and may, depending on size and application parameters, be suitable for use in hollow core concrete. Check with the manufacturer.

Left: The plain version may be set at depth in the concrete. The hole depth is critical as the anchor will move to the base of the hole during setting.

Figure 6: installation of drop-in expansion anchor

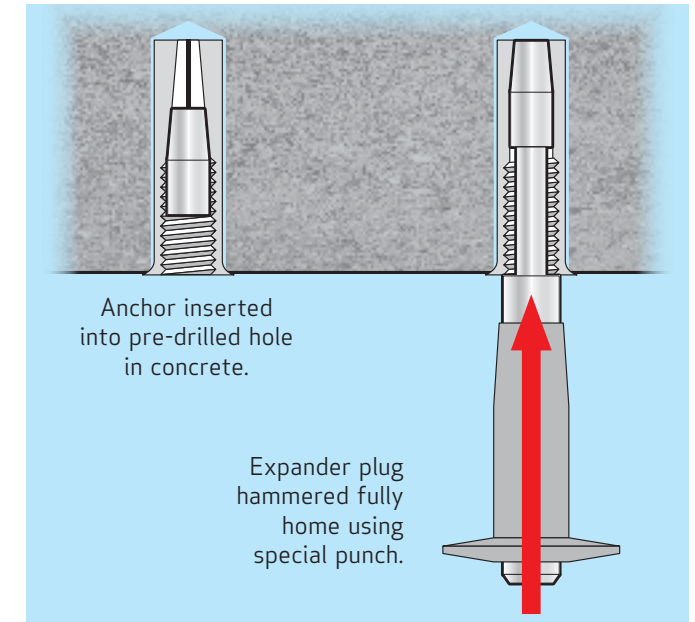

thread engagement without risking the bolt being tightened against the end of the thread otherwise, if tightening continues, the shell of the anchor may be sheared off.

They must not be set too close to the edge of concrete (check with the anchor manufacturer) or the shock loads induced by the hammering action during setting may induce cracks. This is unlikely to be a problem in most cases.

When installing drop-in expansion anchors note that:

- With conventional versions (no lip) hole depth is important
- Some types show a witness mark on the shell when fully expanded

Top fixing types and installation procedures

- Must only be set using the specific setting punch for the make and size of anchor
- Only when the shoulder of the punch meets the shell of the anchor is it fully expanded

5.1.2 Force controlled expansion anchors

This anchor (sometimes known as a wire hanger), which requires a 6mm diameter hole in the soffit, is suitable for use in concrete only and is set by means of a claw hammer (see figure 7). Hole depth must be at least to the manufacturer's recommendations.

Figure 7: installation of force controlled expansion anchor (wire hanger)

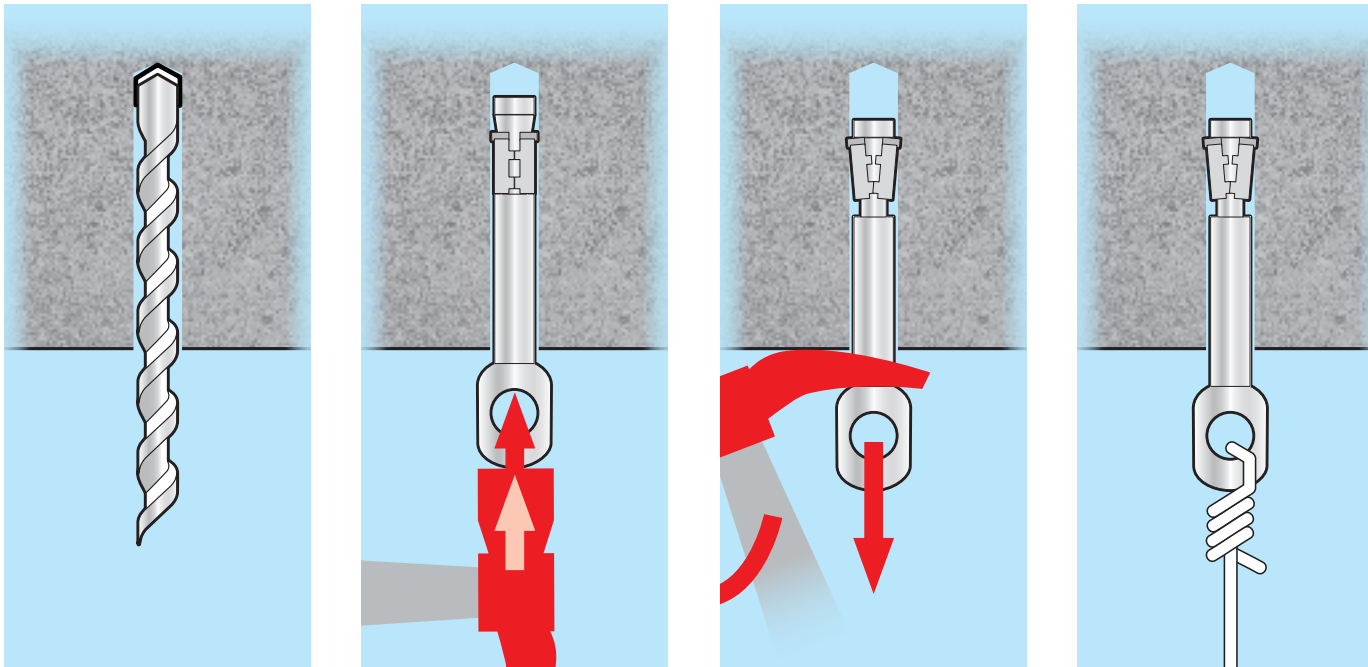

5.1.3 Hammer-in anchors - steel

This anchor is inserted into a pre-drilled hole and expanded by tapping the projecting expander pin until it is flush with the flange. It may be used to fix wire or angle hangers. Anchors made exclusively from steel are available with independently assessed fire resistance data.

Note: some hammer-in anchors with cylindrical expander bodies made of zinc or lead alloys are sometimes supplied for fixing suspended ceilings. These have very poor fire resistance, are prone to load relaxation with time and to failure of the flange during setting or loading. They are frequently referred to as 'metal nail-in' anchors. They are not recommended.

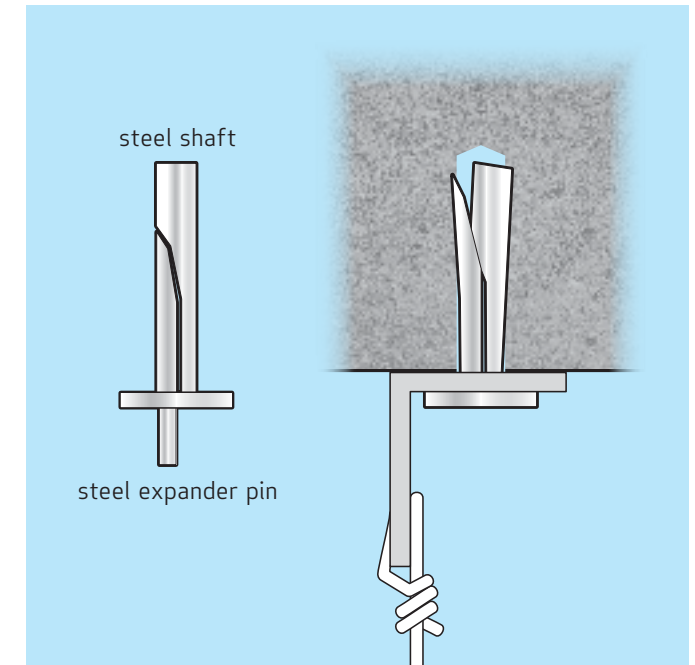

Figure 8: hammer-in anchor used to fix bracket for wire suspension

5.1.4 Hammer-in anchors - nylon (plastic*)

Nylon hammer-in anchors are generally not considered as best practice for top fixing of suspended ceilings due to low strength and poor performance in fire conditions. However, such anchors if qualified with an ETA may be suitable in a variety of solid base materials.

*Nylon is a particular type of plastic recommended for use in anchors. Other forms of plastic may not be suitable.

Top fixing types and installation procedures

5.1.5 Cavity anchors

A selection of cavity anchors is available for use into hollow sections. Most suitable are steel toggle anchors (ETAs are not available on anchors of this type). Manufacturer's guidance should be sought as to which is suited to the particular hollow section concerned. Typically they require a significant space behind the anchor to work, and hole diameters are relatively large compared to bolt diameters. Care is needed when fixing into hollow core concrete and hollow blocks to ensure that the hole is drilled fully into the hollow section or the toggle may not operate as required. In hollow blocks of unknown strength or clay pots, preliminary tests (see 6.1) may be needed to check that the anchors work correctly and to establish allowable loads.

5.2 Screws

5.2.1 Nylon (plastic) plugs and screws

Nylon plugs and screws are generally not considered as best practice for top fixing of suspended ceilings due to low strength and poor performance in fire conditions. However, such fixings if qualified with an ETA may be suitable in a variety of solid base materials.

5.2.2 Self-tapping concrete screws

This type of fixing can be used in cracked concrete as they are available with approval of ETAG 001 Part 3 or Part 6.

They have various head types including threaded studs to accept couplers for drop-rods. The benefits are that they are removable, and simple to install. Self-tapping screws are

commonly available in carbon steel with zinc electroplating some of which will be scraped off during insertion and so are prone to rusting. Therefore if there is any risk of humidity stainless steel versions should be used. Carbon steel concrete screws are generally made from high strength steels which, if over 800N/mm² tensile strength, may suffer from failure due to hydrogen embrittlement especially in damp conditions. They should therefore only be specified in dry internal conditions. Stainless steel versions of self-tapping screws are becoming available.

5.3 Clips and clamps

To complement the extensive range of traditional top fixings that suspended ceilings require, a range of proprietary fixings systems are available to attach to steel sections, with typical loading capabilities as indicated below.

Purlin clips: to suit steel thicknesses of 1mm to 6.5mm and a load capacity of 70kg.

Beam clips: available for steel thicknesses of 2mm to 29mm and a load capacity of 65kg to 90kg.

Beam clamps: utilising an inbuilt holding bolt and offering several threaded rod insert sizes.

One benefit of these systems is that they avoid the need to drill into the steel section. However, if for any reason bolting through the section is necessary then permission to drill should be obtained first from the responsible engineer.

Note: There will be other similar products available that will provide similar solutions. In using all products, mentioned or otherwise, reference should be made to manufacturers for advice on suitability.

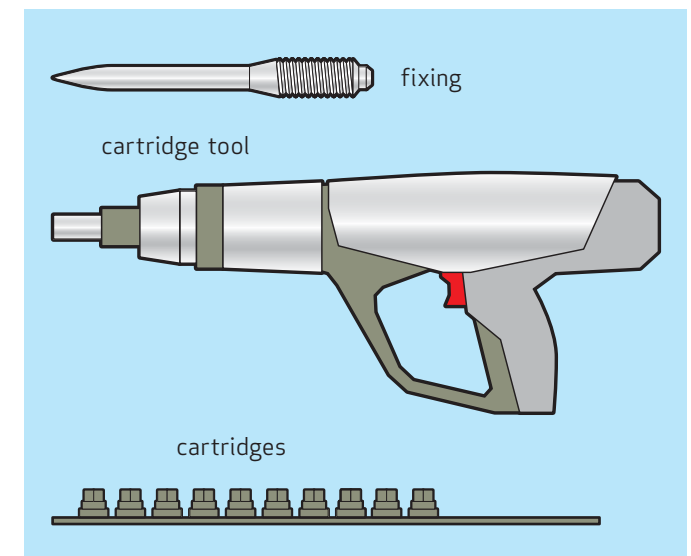

Figure 9a above: shot fired system
Figure 9b right: fixing in concrete

5.4 Powered fasteners

These use modern technologies to drive fixings directly into the base material.

5.4.1 Powder actuated fasteners (also referred to as shot fired)

This system is suitable for providing fixings (threaded stud, nail or bracket mounted on a nail) into concrete, including composite decking, and structural steelwork within certain limitations (see figure 9).

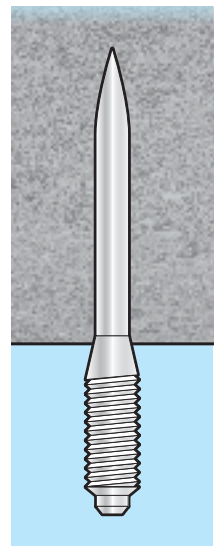

Top fixing types and installation procedures

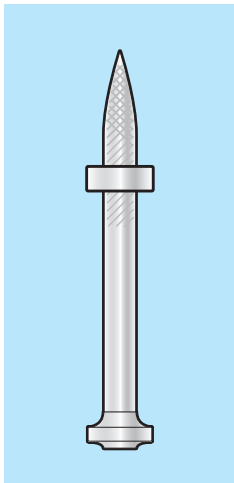

Figure 10: nail, used for permanent fixings

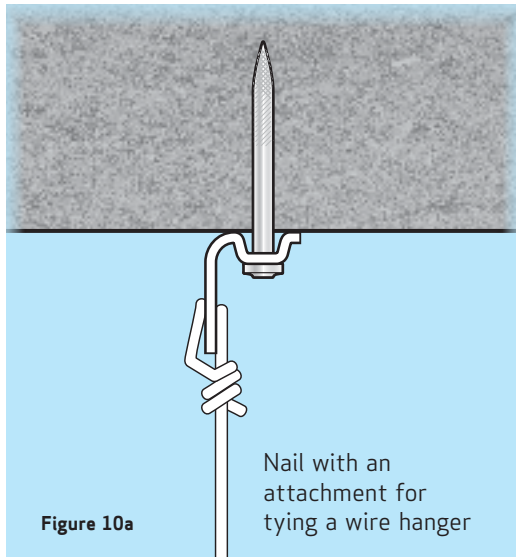

Figure 10a

Nail with an attachment for tying a wire hanger

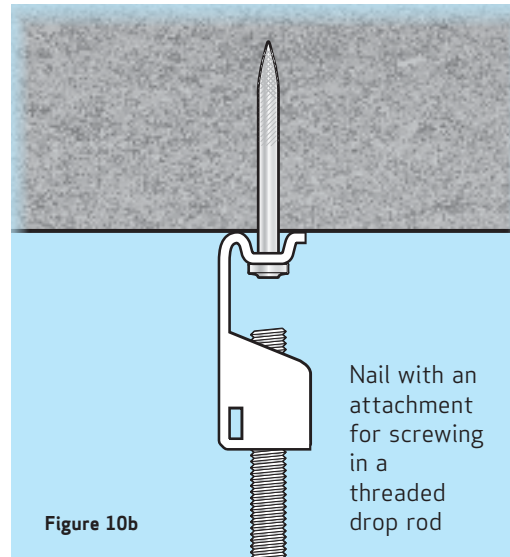

Figure 10b

Nail with an attachment for screwing in a threaded drop rod

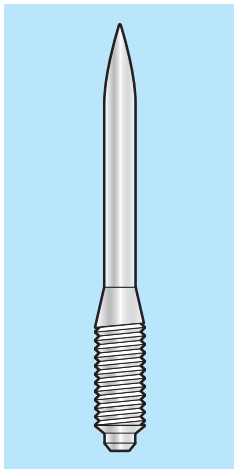

Figure 11: threaded stud for removable fixings

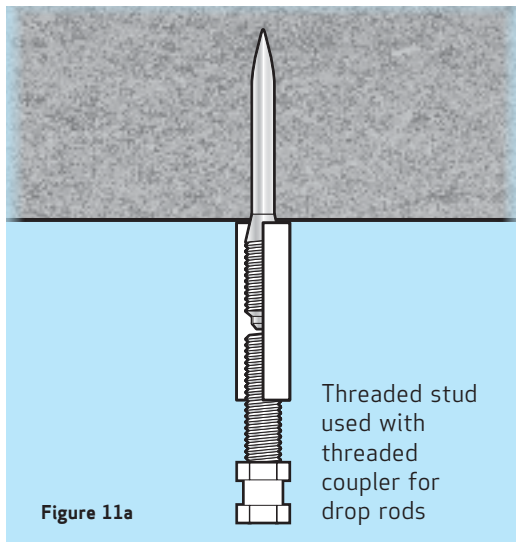

Figure 11a

Threaded stud used with threaded coupler for drop rods

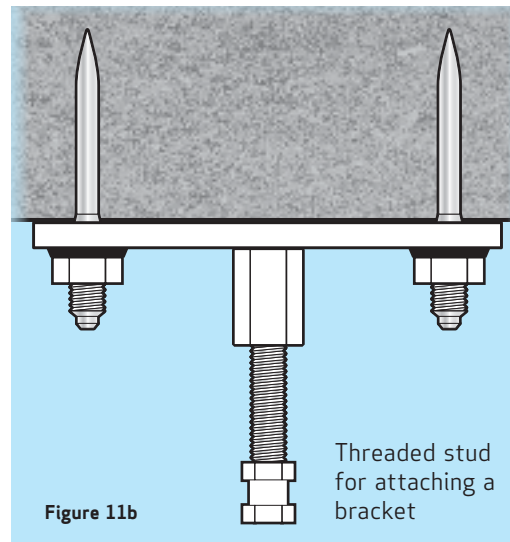

Figure 11b

Threaded stud for attaching a bracket

The fixing and the cartridges are loaded into the tool, the cartridge is fired and this drives a piston, which in turn drives the fixing into the base material. There are safety devices built-in to the tools to ensure the safety of operators and bystanders.

This is a common method of installation and can offer significant cost benefits due to the speed of installation (there are even pole tools available which allow an installer to fix to a concrete soffit while standing on the floor).

There are two types of powder actuated fixings available: nail and threaded stud (see figures 10 and 11).

The use of these fasteners must be part of the initial design and not the choice of the contractor. Manufacturer's recommendations must be followed at all times.

It is strongly recommended that all operators of these tools are trained and certified by the manufacturer or supplier of the tool. This training covers the safe use of the tool which includes the requirements for obtaining a good fixing.

5.4.1.1 Standard installation method

For the normal use of these tools, the fixing is loaded followed by the correct cartridge (and power setting). The front of the tool is positioned where the fixing is needed and the contact pressure is taken up (the tools will not fire unless the required pressure and movement is applied). The tool is then fired by pressing the trigger and the fixing is made.

The presence of aggregates close to the surface of concrete structures (especially under soffits) causes a certain proportion of these fasteners to deflect. This

Top fixing types and installation procedures

deflection may result in inconsistent results and a significant reduction in holding power including the complete failure of a proportion of fixings. For this reason it is recommended that the manufacturer be involved on every project to recommend an approach to the design, the installation and testing regime. This approach should take into account the fact that top fixings for suspended ceilings are invariably made into concrete that is cracked.

This guide recommends the following approach:

DESIGN

To cater for the inconsistency of holding power and possibility of failure a multiple fastening approach should be adopted to ensure that the failure of one fixing results in load transfer to adjacent fixings. To achieve this in practice it is recommended that a minimum of five fixings are used per main runner. This may mean that hangers need to be set at centre spacings closer than 1200mm.

INSTALLATION

Prior to installation test fixings should be carried out to ensure that the correct combination of fastener length and cartridge strength are used for the particular concrete conditions of the job. An embedment depth of between 22mm and 32mm should be achieved. The deeper the embedment depth that can reliably be achieved the stronger the fixings will be. Powder actuated fixings should not be made closer than 80mm from the edge of a concrete section. A pre-drilled approach may be a means of significantly reducing the deflection caused by aggregates (see 5.4.1.2).

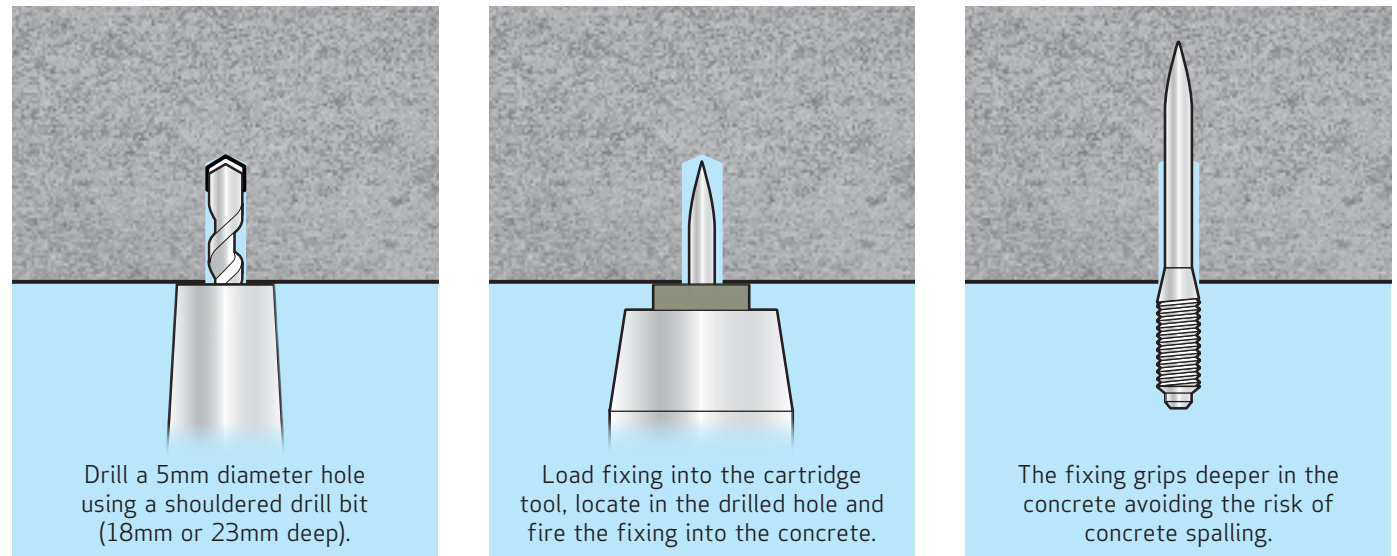

Figure 12: typical pre-drilled system

TESTING

As the deflection referred to above is not always obvious a tug test is recommended, in which the installer tugs every hanger to make sure that each fixing is secure. (This is in addition to the proof testing recommended in section 6.2.)

Fixings made in composite decks (ie through metal decking into concrete) are likely to suffer less deflection and be more consistent, however care should still be exercised when fixing through metal decking into concrete as any effects of poor concrete placement cannot be seen and the fixing may be made into a void.

There are, as yet, no ETAs for this type of fixing into concrete, either cracked or non-cracked, but there are for some fixings into steel. Test fixing should be carried out to

ensure the most appropriate combination of shank length and cartridge strength is used.

5.4.1.2 Pre-drilled system

The basic use of the tool is as the standard installation procedure, but the fixing is installed into a pre-drilled hole which makes the installation more reliable and single point fixings allowable. It therefore becomes a two-stage operation, requiring a small hole to be drilled (special drill bits are available for this) and the fixing installed and driven to the required embedment depth (**see figure 12**) typically around 48mm. This installation method is not as fast as the simple powder activated method, however, it is much more reliable, and this allows for single point fixings.

Top fixing types and installation procedures

5.4.1.3 Fixings into structural steelwork

When fixing into structural steelwork, the steelwork should be a minimum of 4mm thick. Powder actuated fixings should not be made closer than 15mm from the edge of a steel section.

Special fasteners are available for fixing into structural steelwork, they have shorter shanks, to achieve embedment depths between 10mm and 14mm with a knurled finish to improve grip (see figures 13 and 14).

Test fixings should be carried out to ensure the most appropriate shank length and cartridge combination is used.

5.4.2 Gas powered fasteners (gas nailing)

These work on the same principle as cartridge tools except that the driving power comes from the explosive force

Figure 13: fasteners for fixing into structural steelwork

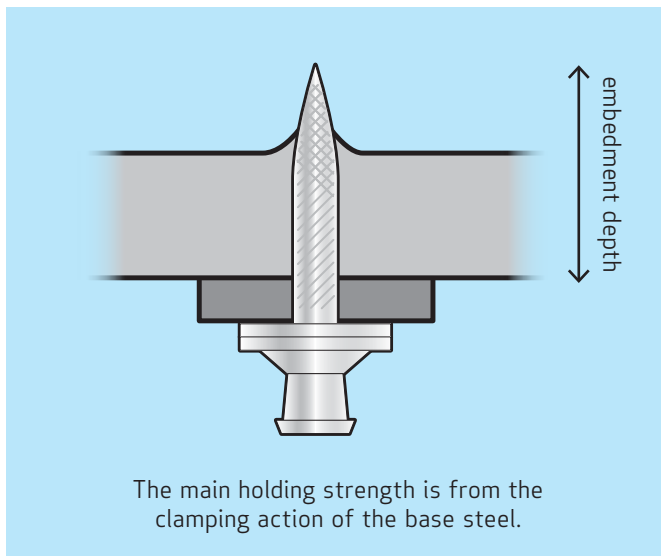

created by igniting gas in a confined chamber. This type of fixing is not recommended for general fixings for suspended ceilings or steelwork as the systems currently available are not capable of achieving the embedment depths required.

Gas nailing systems are suitable for light duty electrical applications or fixing drywall track to ceilings.

5.5 Cast-in channel

Cast-in channels range from simple self-anchoring slots for accepting restraint fixings to large capacity channels with integral fixings (see figure 15). They provide the necessary adjustment required when fixing to concrete and can eliminate site drilling. Here proprietary fixings designed for

Figure 14: fasteners for fixing into structural steelwork

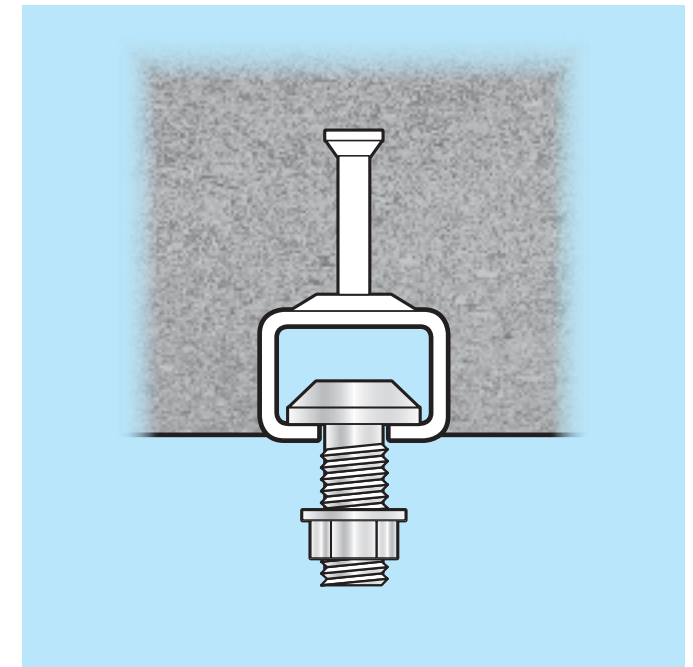
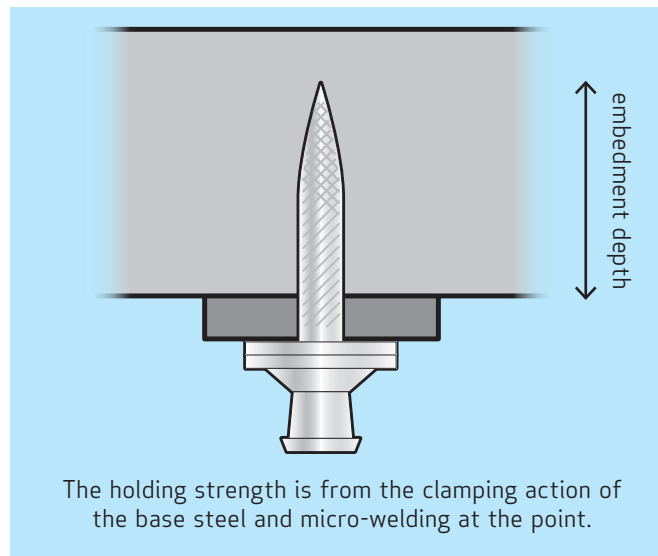

Figure 15: typical cast-in channel

use with individual channels should be used. As with all top fixings the design of the channel and fixing should take into account the applied load.

Top fixing types and installation procedures

5.6 General installation

It is necessary for the contractor to be able to demonstrate that all top fixings have been correctly installed. This means that fixings should be installed only by competent installers who have been trained in the particular method needed for the fixing concerned - using the correct tools and strictly in accordance with the fixing manufacturer's instructions.

Key aspects are:

- Drill holes to correct diameter and depth
- Clean holes strictly in accordance with the manufacturer's instructions
- Set in accordance with the manufacturer's setting instructions using the correct tools
- Tighten to the recommended installation torque, where appropriate, using a calibrated torque wrench

5.6.1 Hole dimension

Hole dimensions can be critical. Drill bits should be used in accordance with the manufacturer's instructions. This guidance recommends that drill bits bear the PGM mark, which gives assurance that the drill has been manufactured to agreed tolerances www.pgm-online.org

Hole diameter must be right to ensure the fixing works and gives the expected performance. Hole depths in particular must be specified carefully in drawings or on method statements as this affects not only the capacity of the fixing but the ability of fixings using bolts to engage properly. Follow the manufacturer's instructions. For many fixings the hole depth is governed by the required embedment depth.

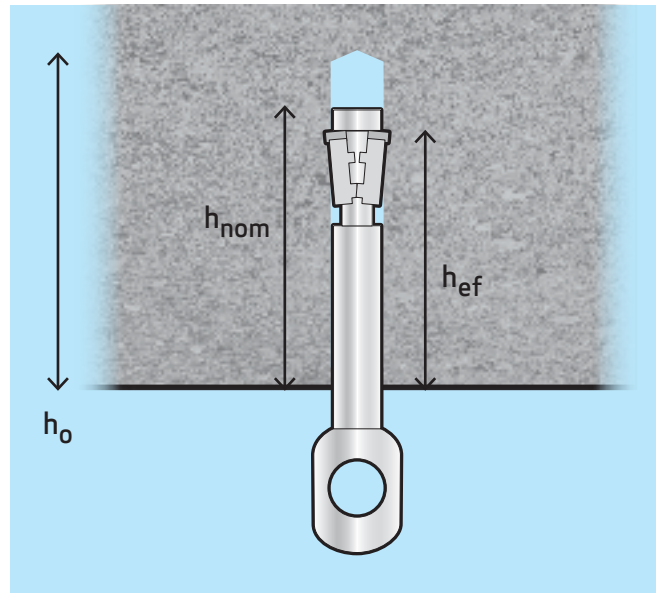

Figure 16: illustration of different notations for embedment depths

5.6.2 Embedment depths

Figure 16 illustrates the difference between embedment depth h_{nom} (the deepest point the fixing reaches), effective embedment depth h_{ef} (the depth of the deepest point engaging with the substrate), and hole depth h_o . Fixing performance is usually dependent on effective embedment depth h_{ef} .

This terminology is common to most manufacturers. Specifiers and users should ensure they are familiar with these terms.

Embedment depths in concrete are straightforward and should follow the manufacturer's recommendations.

5.6.3 Competent installer scheme

It is intended that this best practice guide forms the basis of a competent installer training scheme, whereby operatives are trained in all aspects of the correct selection and installation of top fixings for suspended ceilings. At the time of publication, CITB-ConstructionSkills and AIS were investigating the feasibility of such a scheme.

Testing top fixings on site

Site tests may be needed for two main purposes - to check the suitability of a particular fixing (preliminary tests) and to check the quality of installation (proof tests).

6.1 Preliminary tests

Preliminary tests are required only when there is no recommended load data available for the proposed fixing. As most top fixings are installed into concrete, for which manufacturers recommended load data will be available, preliminary tests are rarely required and only for the following cases:

- Beam and block ceilings - top fixings into blocks of unknown strength
- Perimeter trim fixings into brickwork or blockwork
- Powder actuated fixings

Preliminary tests are normally only required for tensile loads. Refer to the manufacturer in the case where shear loads are to be applied and there is no recommended shear load data.

OBJECTIVE

The objective of preliminary tests is to determine the allowable load by carrying out the minimum number of tests that can give a safe result, while applying a test load designed to minimise the possibility of damage to the base material.

PROCEDURE

The procedure is outlined in more detail in 'CFA Guidance Note: Procedure for site testing construction fixings - 2012', available from www.fixingscfa.co.uk/guidancenotes.asp

Five sample fixings (which will not be used on the job) should be tested in each different base material of the project in areas well away from where working fixings will be located.

All top fixings should be carefully test loaded to three times the applied load (five times applied load in the case of nylon fixings which require higher test factors due to particular characteristics of nylon).

If the test load is held without significant movement the proposed fixing may be used for the applied load at the designed centre spacings. If any one of the five tests fails to reach the test load then the person responsible for the fixing design for the project should be consulted.

POSSIBLE COURSES OF ACTION FOLLOWING ONE FAILURE DURING PRELIMINARY TESTS:

- a** use a fixing of the same type but with a deeper embedment depth*
- b** use a fixing of the same type but with a larger diameter*
- c** use a different type of fixing*
- d** use the original fixing specification but with an allowable load derived from further tests as below, this may involve a ceiling redesign to reduce the loadings by for instance fixing at closer centres eg 600mm rather than 1200mm.

* For any solution **a**, **b** or **c** a new series of preliminary tests must be carried out.

PROCEDURE IN THE CASE THAT OPTION **d** IS CHOSEN:

- Each fixing in the original sample of five tests that held the test load should now be carefully loaded to failure giving a total of five failure loads

- Determine the allowable load from the lowest of the following values:

For all except nylon fixings:

- The average failure load ÷ 4 or
- The lowest failure load ÷ 3

For nylon fixings:

- the average failure load ÷ 7 or
- the lowest failure load ÷ 5

The failure load is taken as the maximum load reached during the test or the load at approximately 1mm movement in the case where a fixing pulls out of the base material.

Note: allowable loads determined from tests on one job should never be considered suitable for the design of another job unless the base material is known to be identical.

The new allowable load must then be made known to the designer who should decide on the best course of action.

6.2 Proof tests

Proof tests are needed to check the quality of installation of the chosen fixing, and should be carried out on all projects.

6.2.1 Fixings other than powder actuated fasteners

A sample of fixings to be used shall be tested to a load of 1.5 times the applied load. Working fixings should never be loaded to more than 1.5 times the recommended load. The pass criterion is that no significant movement of the fixing is apparent - a visual check only is sufficient.

Testing top fixings on site

A minimum of three fixings should be tested and at least 5% (one in 20), chosen at random and spread evenly throughout the whole job.

The minimum number (three) applies to every discreet area where:

- a** different fixings (correctly selected) may have been used
- b** the base material is different
- c** a different team of installers has worked

Installations made in different rooms should be regarded as a discreet area needing the minimum number of tests to be carried out.

The failure of a fixing in proof testing is a serious issue and requires the investigation of the cause(s) of failure and an increase in testing rate. BS 8539 recommends:

- One failure - double the test rate to one in 10 and a minimum of six
- More than one failure - test 100% of the job, review the fixing specification and installation method

Site tests should be carried out by a suitably competent person(s) (other than the actual installer of the fixings tested).

For test loads over 0.25kN tests can be done using a test meter mounted on a bridge or, for test loads up to 0.25kN (light weight ceilings <10kg/m²) by the use of a simple spring balance such as indicated in **figure 17**, or by careful use of weights. All test equipment should be calibrated within the last 12 months to an accuracy of <5%.

Test equipment should apply the load through suitable couplers and be arranged such that the reaction loads are taken sufficiently far from the top fixing so as not to

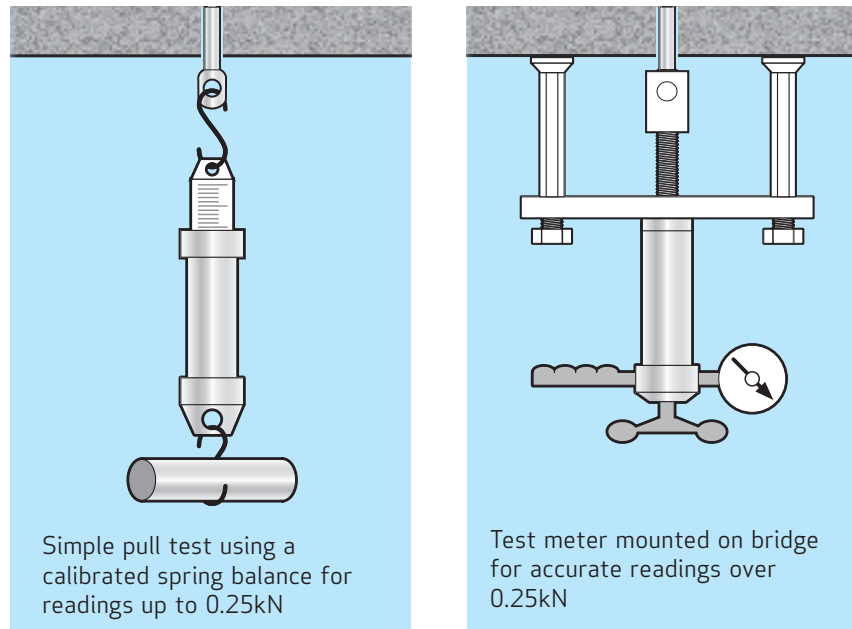

Figure 17: typical test rig arrangements

influence the result (typically 1 x embedment depth, h_{ef}). Gauges should have an appropriate range such that test loads are greater than 20% of the full scale reading. Gauges calibrated to full scale deflection of 1kN (for loads from 0.2 to 1.0kN) or 5kN (for loads of 1.0 to 5kN) are available for commonly used equipment. Tests loads should be applied in such a manner as to ensure the safety of all personnel in the event of the failure of a top fixing.

Note: the 'CFA Guidance Note: Procedure for site testing construction fixings - 2012' contains guidelines for site testing of fixings. Test fixings should be installed strictly in accordance with the manufacturer's

recommendations. Test results should be formally recorded and retained with documentation relating to the project.

6.2.2 Powder actuated fasteners

In addition to the proof testing requirements of 6.2.1, best practice dictates that when using powder actuated fasteners each fixing is checked to be secure by the installer. A tug test, where the installer tugs the hanger to make sure that it is secure, is sufficient.

Total ties on the job	Number of proof tests
0-60	3
61-80	4
81-100	5
101-120	6
121-140	7
141-160	8
161-180	9
181-200	10
200-220	11
221-240	12

Terminology

In this guide the terms listed are taken to have the following meanings:

Allowable load

The load which may be applied to the fixing as determined from 'preliminary tests' on site when there is no 'recommended load' data available for the base material concerned. Referred to in BS 8539 as 'allowable resistance'.

Anchor

A manufactured, assembled component for achieving a connection between the base material and the fixture (BS 8539 definition). Also referred to as 'fixing'.

Anchorage

The combination of a fixing, a fixture (eg a bracket), and the immediately surrounding base material on which the fixing depends in order to transfer the relevant forces.

Applied load

Actual load to be applied to the fixing according to the design (service load). Is a combination of the dead and imposed loads. Referred to in BS 8539 as 'characteristic action'. Should not be confused with 'design action'.

Base material

Load bearing structural element, eg concrete slabs, hollow core floor slabs, steel beams. Sometimes referred to as substrate.

Ceiling hanger

A suspension component connected to the soffit and primary support ceiling channel, eg strap, wire, angle. Hanger (angle), typically used for medium and heavyweight suspended ceilings and where increased suspension depth is required.

Characteristic action

(Term used in BS 8539) load applied by the fixture to the fixings, referred to in this guide as 'applied load', also known as 'unfactored load'.

Characteristic permanent action

Permanent component of characteristic action, commonly known as 'dead load'.

Characteristic variable action

Variable component of characteristic action, commonly known as 'imposed load' or 'live load'.

Competent person

A person with the skill, knowledge, practical experience and training to carry out the required tasks.

Contractor

Person or organisation responsible for the overall installation of the suspended ceiling.

Dead load

Total self weight of the suspended ceiling system, eg ceiling board, framing, suspension and insulation (if applicable).

Designer

Person responsible for the overall design of the suspended ceiling in its installed condition.

Design action

Load derived from the characteristic action by application of a partial safety factor (usually taken to be 1.4) for the action. Sometimes known as 'factored load'.

Disproportionate collapse

A collapse, after an event, which is greater than expected given the magnitude of the initiating event. Eg a ceiling would not be expected to collapse if a door were slammed.

ETA

European Technical Approval (will be become European Technical Assessment on the introduction of the Construction Products Regulation (CPR) to be implemented in July 2013).

Fixing points

Positions at which the hangers are required in accordance with the manufacturer's instructions.

Fixture

Element fixed to the load bearing structure by a fixing eg bracket.

Heavy weight suspended ceiling

A suspended ceiling with a dead load in excess of 30kg/m² eg multi layer plasterboard.

Installer

Person who installs the top fixings.

Imposed load

Additional weight that is not part of the dead load of the suspended ceiling system, eg lighting, grilles, ducting.

Light weight suspended ceiling

A suspended ceiling with a maximum dead load of 10kg/m².

Medium weight suspended ceiling

A suspended ceiling with a maximum dead load of between 10kg/m² and 30kg/m².

Proof tests

Tests carried out on site on a sample of installed fixings, to check that they have been installed correctly.

Preliminary tests

Tests carried out on site, prior to installation, as part of the selection process.

Progressive collapse

The sequential spread of local damage from an initiating event, from element to element, resulting in the collapse of a number of elements. Whilst undesirable, a progressive collapse may not be disproportionate. Hence the term 'progressive collapse' is not necessarily equivalent to 'disproportionate collapse'. Collapses may be progressive and disproportionate.

Purlin

In architecture or structural engineering or building, a purlin (or purline) is a horizontal structural member in a roof. Purlins support the loads from the roof deck or sheathing and are supported by the principal rafters and/or the building walls, steel beams etc. The use of purlins, as opposed to closely spaced rafters, is common in pre-engineered metal building systems and both the ancient post and beam and newer pole building timber frame construction methodologies.

Recommended load

The load which may be applied to the fixing as quoted by the manufacturer for a specific base material.

Redundant fixing

A fixing whereby if it fails it will not result in collapse of the element.

Redundancy

A term used to signify that there are more load paths than strictly necessary to carry the load through the structure, or part thereof. In structural analysis redundancy is associated with structural indeterminacy, but in the context of robustness the term has a wider meaning and interpretation.

Robustness

A quality in a structure/structural system that describes its ability to accept a certain amount of damage without that structure failing to any degree. Robustness implies insensitivity to local failure. BS EN 1991-1-7 provides one

definition of robustness as "the ability of a structure to withstand events like fire, explosions, impact or the consequences of human error without being damaged to an extent disproportionate to the original cause".

Secondary suspended ceiling

A second non-loadbearing ceiling hung by suspension from the initial suspended ceiling.

Suspension component

Part of the substructure, connecting it to the load bearing structure.

Supported structure

The primary grid, a single length or individual lengths such as main tees.

Specifier

Person responsible for selecting the top fixing. May be the ceiling designer.

Sound mass barrier

A heavyweight suspended ceiling system comprising multiple layers of plasterboard for sound insulation purposes.

Structure

The arrangement of slabs, beams columns and or walls which carry the loads from the building.

Substrate

'Base material' into which fixings are installed.

Suspension points

See 'fixing points'.

Suspended ceiling

A non-load bearing ceiling hung by suspension from the substrate.

Threaded rod

Rigid suspension hanger fixed direct to the substrate to provide structural support for suspending ceilings and independent support for other imposed loads, eg cable trays, ductwork, walk on ceilings.

Top fixing

Any fixing used to connect the suspension components to the load bearing structure.

Tug test

This is a simple test carried out on powered fasteners to detect failures.

Walk-on ceiling

A load bearing ceiling providing structural support to enable maintenance of services within the ceiling void.

Wire

Hanger, typically used for light weight suspended ceilings.

For more information on the terminology used in this guide and in documents referring to fixings (including BS 8539) see 'CFA Guidance Note: Construction Fixings Terminology and Notation explained', available to view at www.fixingscfa.co.uk/guidancenotes.asp

Contracting support administration

8.1 Sustainability

All construction projects over a certain value will have a sustainability / carbon footprint agenda which will have to be embraced by all specialist contractors to share in the process.

As a best practice principle, all specialist contractors should have an ongoing carbon footprint reduction programme, which can then become applicable on all projects. This will include the disposal of all materials from the strip out, and offcuts from the installation. Materials may be selected to comply with systems that are designed to measure the environmental impact of the fit out such as Ska (see section 9).

8.2 Health and safety

To conform to the Health & Safety at Work Act 1974 the specialist contractor and main contractor must provide a method statement and risk assessment of the work that has to be undertaken on each project. All members of the construction team have a duty of care to their site colleagues.

Working to agreed programmes and to formalised method statements can contribute to site safety. Identifying hazards and assessing potential risks should cover the working environment, the work to be done, the tools and equipment to be used and the materials to be installed.

Guidance can be sought from the 'AIS Health & Safety Handbook' and also the 'AIS Site Guide for Suspended Ceilings', which has particular reference to working at height.

8.3 Operation and maintenance (O&M) manuals

When work has been completed, it is good practice to obtain signatures from the main contractor on a completion / handover certificate, to avoid later disputes on any damage subsequently caused by other trades.

If required by the terms of engagement, the main contractor must provide, either in paper form or more commonly via computer files, information relevant to the installation that has been carried out.

Typically this includes:

- Products installed
- 'As built' drawings
- Manufacturers' product information, including source of replacement material, and advice on cleaning, maintenance, repair and disposal of materials for recycling at end of life
- Acoustic and fire performance details
- Details of any special elements to the project
- Advice on removal and replacement of tiles
- Relevant COSHH data

References

Ska

Lead and owned by the Royal Institution of Chartered Surveyors (RICS) the Ska Rating is an assessment method, benchmark and standard for non-domestic fit outs. It helps landlords and tenants assess fit out projects against a set of sustainability good practice criteria.

Ska Offices is used on fit out projects large and small, both refurbishment and new build, and it scores environmental good practice irrespective of the base building. The offices scheme consists of 104 individual good practice measures covering Energy and CO2 Emissions, Waste, Water, Materials, Pollution, Wellbeing and Transport.

Ska Rating for Retail is suitable for fit-out projects of any size in existing or new buildings and for one-off projects or multi-store roll out programmes including:

- Food retail
- Non-food retail
- Retail banks
- Restaurants.

This guidance is freely available along with an online assessment tool, which can be used informally or for formal certification using an RICS Ska Rating Accredited Assessor. Assessments can be carried out at three stages: design, handover and occupancy.

AIS is a Ska development partner.

www.rics.org/ska

SCOSS

The Standing Committee on Structural Safety is the independent body established in 1976 to maintain a continuing review of building and civil engineering matters affecting the safety of structures. SCOSS aims to identify in advance those trends and developments which might contribute to an increasing risk to structural safety.

CROSS

Confidential Reporting on Structural Safety is the scheme established by SCOSS in 2005 to improve structural safety and reduce failures by using confidential reports to highlight lessons that have been learnt, to generate feedback and to influence change. Reports sent to CROSS are completely confidential and separate from SCOSS, and neither personal details nor information that could be used to identify a project or product are used.

www.structural-safety.org

Standards

BS 8539: 2012 - Code of practice for the selection and installation of post-installed anchors in concrete and masonry. (Due for publication at end of 2012).

BS EN 13964: 2004 - Suspended ceilings - requirements and test methods (Section 4.3.4 and Annex B).

Useful websites:

Standing committee on structural safety

www.structural-safety.org

HSE Updates

www.hse.gov.uk/news/index.htm

The Building Services Research and Information Association

www.bsria.co.uk

Useful publications:

There are a series of fact files to support this document:

- Specifier's quick guide to top fixings for ceilings
- Installer's quick guide to top fixings for ceilings
- Report formats for preliminary and proof testing

AIS Best practice guide: installation of suspended ceilings

www.ais-interiors.org

CFA Guidance Notes on fixings related issues

www.fixingscfa.co.uk

Appendix

10.1 ETAG 001: Metal anchors for use in concrete - part 6 - anchors for multiple use for non-structural applications

ETAG 001 Part 6 contains the following definition of multiple use:

“The design of the fixture is such that, in the case of excessive slip or failure of one anchor, the load can be transmitted to neighbouring anchors without significantly violating the requirements on the fixture in the serviceability and ultimate limit state.

For example the design of the fixture may specify the number n_1 of fixing points to fasten the fixture and the number n_2 of anchors per fixing point. Furthermore by specifying the design value of actions on a fixing point to a value n_3 (kN) up to which the strength and stiffness of the fixture are fulfilled and the load transfer in the case of excessive slip or failure of one anchor need not be taken into account in the design of the fixture.”

$n_1 > 4$; $n_2 > 1$ and $n_3 < 3.0\text{kN}$ or
 $n_1 > 3$; $n_2 > 1$ and $n_3 < 2.0\text{kN}$

Where n_1 is the number of fixing points, n_2 is the number of anchors per fixing point, and n_3 is the design action (factored load) per fixing point. (The design action is derived from the characteristic action by the application of a partial safety factor, usually taken as 1.4.)

In practice what this means is:

When there are at least four fixing points along a row carrying a single tee or other longitudinal member, and each

fixing point has at least one anchor, the design action per fixing point may not exceed 3kN (see figure 18).

When there are at least three fixing points with at least one anchor per fixing point the design action per fixing point may not exceed 2kN (see figure 19).

As long as these criteria are met the stiffness of the tee or longitudinal member need not be considered. When n_1 (number of fixing points) is, in the case of a typical main tee, three, and n_2 (number of anchors per fixing point) is one per angle bracket then n_3 = design action (factored load) per fixing point which in the case of a:

- **Light weight ceiling*** with a dead load of, for example, 10kg/m² is a factored load of 20.2kg per fixing point or 0.2kN

Figure 18: Illustration of ‘multiple use’ as defined in ETAG 001 Part 6 for the case n_1 = at least four fixing points

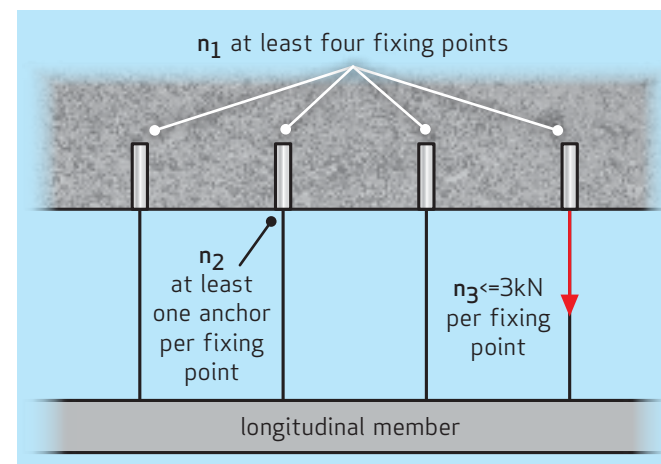

- **Medium weight ceiling*** with a dead load of, for example 20kg/m² is a factored load of 40.3kg per fixing point or 0.4kN
- **Heavy weight ceiling*** with a dead load of, for example 30kg/m² is a factored load of 60.5kg per fixing point or 0.6kN

* All examples are assumed to be 1200mm square grids.

In all three examples the result is less than 2.0kN and hence the design is satisfactory so far as this criterion is concerned.

The maximum dead weight of a ceiling that would satisfy the criteria of the above definition of multiple use and not exceed a factored load of 2.0kN on a 1200mm square grid is 140kg/m².

Figure 19: Illustration of “multiple use” as defined in ETAG 001 Part 6 for the case n_1 = at least three fixing points

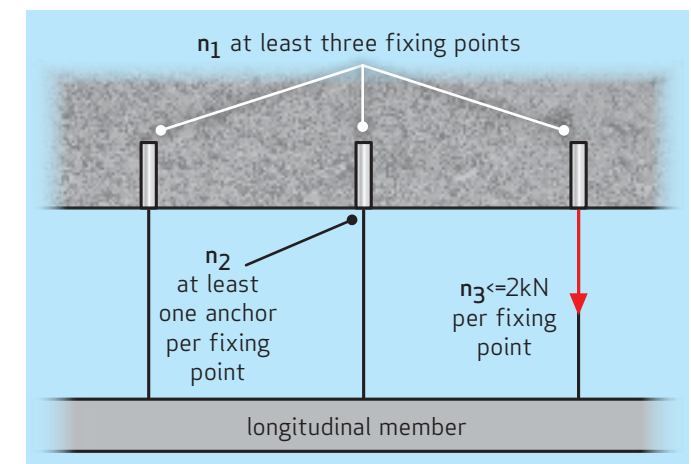

Acknowledgments



About AIS

The Association of Interior Specialists (AIS) has grown over the past 50 years to become the leading trade association for the interiors fit out sector of the construction industry. AIS represents companies involved in the manufacture, supply and installation of all aspects of interior fit outs and refurbishment.

AIS members operate in retail and commercial offices, the public sector, banks and building societies, hotels and leisure, airports, hospitals, and so on. Most work nationally and an increasing number operate in Europe and beyond.

Quality and integrity lie at the heart of AIS's philosophy - each member is expected to act with the utmost integrity, and to exercise the highest standards of business practice and workmanship. At the same time, the Association seeks to continually raise, maintain and ensure the perpetuation of standards in order to remain a source of quality membership.

AIS membership is not automatic and applicants are subject to strict vetting procedures on application, as well as ongoing vetting. In the case of contractors, this includes inspection of recent contracts to assess workmanship standards.

www.ais-interiors.org.uk



About CFA

The Construction Fixings Association (CFA) represents the major manufacturers of fixing systems sold in the UK and which are set in drilled holes in all construction materials including concrete, brickwork, blockwork, stonework and plasterboard - many with European Technical Approvals (ETAs). Its mission is to ensure best fixings practice. Ever since its inception in 1979 the CFA has been involved with national bodies such as BSI, BSRIA, CIRIA, BBA and European bodies including EOTA and CEN, and co-operates with industry bodies to produce guides such as this one which are specific to the requirements of particular industry applications.

The Association publishes a wealth of information on all aspects of the correct use of construction fixings which may be freely downloaded from

www.fixingscfa.co.uk

The following organisations have also been instrumental in the production of this document:

AD Design Consultants Ltd

www.addc-ltd.co.uk

Association for Specialist Fire Protection (ASFP)

www.asfp.org.uk

Imperial College London

www.imperial.ac.uk

Standing Committee on Structural Safety (SCOSS)

www.scoss.org.uk

AIS and CFA would also like to extend their thanks to those members and other professionals and specialists who gave generously of their valuable time and expertise to make this publication possible.

Supported by



Association of Interior Specialists Construction Fixings Association

BEST PRACTICE GUIDE selection and installation of top fixings for suspended ceilings

Association of Interior Specialists

Olton Bridge
245 Warwick Road
Solihull
B92 7AH

Tel: 0121 707 0077
Fax: 0121 706 1949
Email: info@ais-interiors.org.uk
Website: www.ais-interiors.org.uk

ISBN 978-0-9565341-3-2

Construction Fixings Association

65 Deans Street
Oakham
Rutland
LE15 6AF

Tel: 01664 823687
Fax: 01664 823687
Email: info@the-cfa.co.uk
Website: www.fixingscfa.co.uk